

TODD TOWNSHIP
RECOMMENDED MINIMUM SECTIONS FOR TOWNSHIP MAINTAINED ROADWAYS

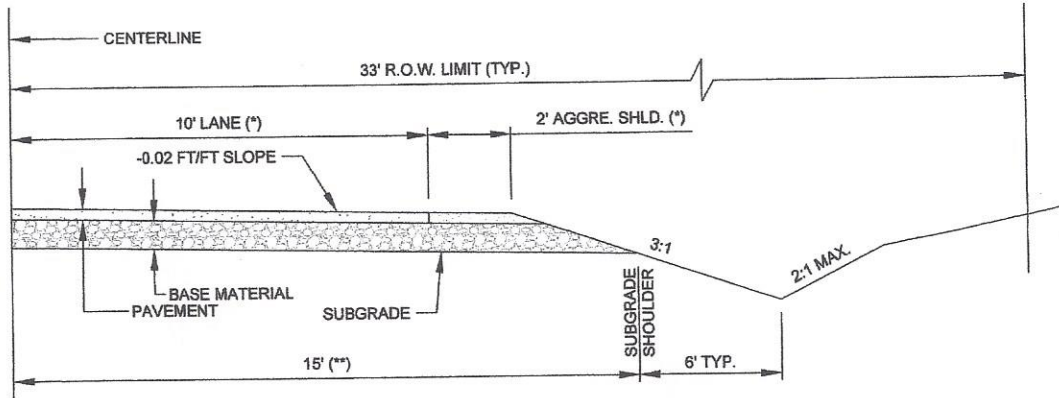

TYPICAL SECTION FOR BITUMINOUS PAVEMENT
NOT TO SCALE

CONSTRUCTION NOTES:

Pavement type and thickness shall be in accordance with MNDOT Best Practices for the Design and Construction of Low Volume Roads or by other recommended methods for low volume roads.
 (*) As noted above in the drawing, the lane and shoulder widths may vary to 11 feet and 4 feet respectively depending on ADT.
 (**) Subgrade width can vary to 18 feet.
 Typically in Todd Township it will be as shown above.
 Type or class of base material, its thickness, and compaction requirements shall be as specified in the design.
 Shoulder material shall be MNDOT Spec.3138 (Class 1) and be compacted as specified in the design.
 Subgrade cross slopes will be the same as the driving surface and shall be compacted as specified.
 Minimum cover over all culverts shall be 1 foot measured from the subgrade shoulder. This requirement may mean that the prescribed ditch depth may exceed that specified.
 No deleterious material (i.e., stumps, brush, clay lumps etc.) shall be incorporated in the subgrade.
 If superelevation is necessary it shall be in accordance with MNDOT Design Manual Chapter 3.

TODD TOWNSHIP
RECOMMENDED MINIMUM SECTIONS FOR TOWNSHIP MAINTAINED ROADWAYS

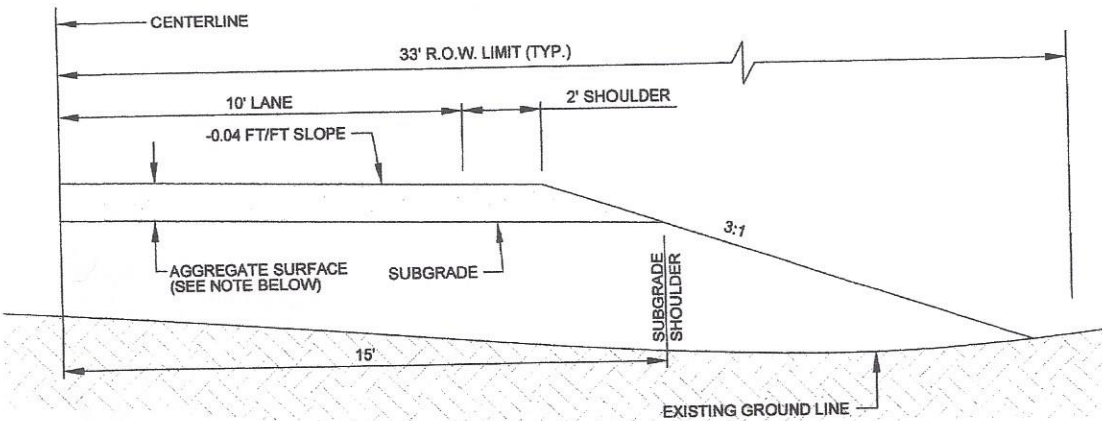

TYPICAL FILL SECTION FOR AGGREGATE SURFACED ROADWAY
NOT TO SCALE

CONSTRUCTION NOTES:

Thickness of the Class 1 surfacing shall be in accordance with the following or as may be specified by the Design Engineer.
 Minimum 4 inches of compacted surfacing (MNDOT 3138 Class 1) with a sand or gravel subgrade.
 Minimum 6 inches of compacted surfacing (MNDOT 3138 Class 1) with other soil types.
 Subgrade shall be compacted as specified by the Design Engineer and slope shall follow the aggregate surface slope.
 Minimum cover over culverts shall be 1 foot measured from the subgrade shoulder.
 No deleterious material (i.e., stumps, brush, clay lumps etc.) shall be incorporated in the subgrade.

TODD TOWNSHIP

RECOMMENDED MINIMUM SECTIONS FOR TOWNSHIP MAINTAINED ROADWAYS

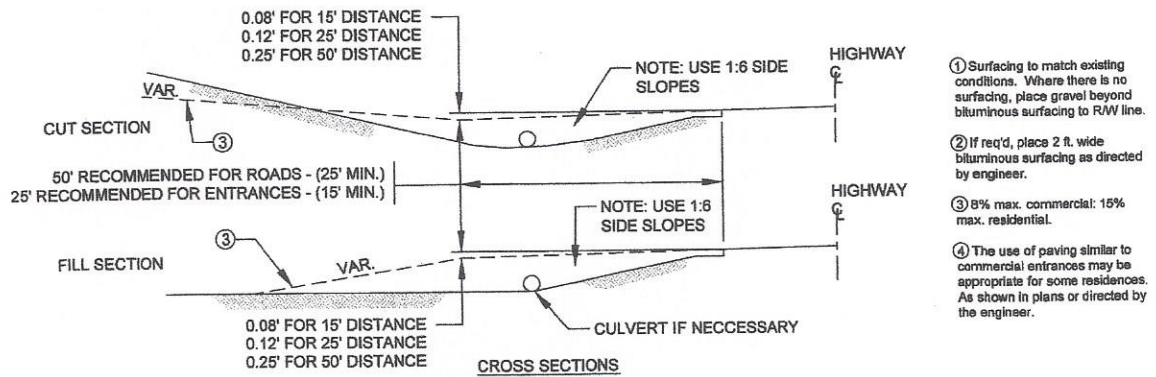
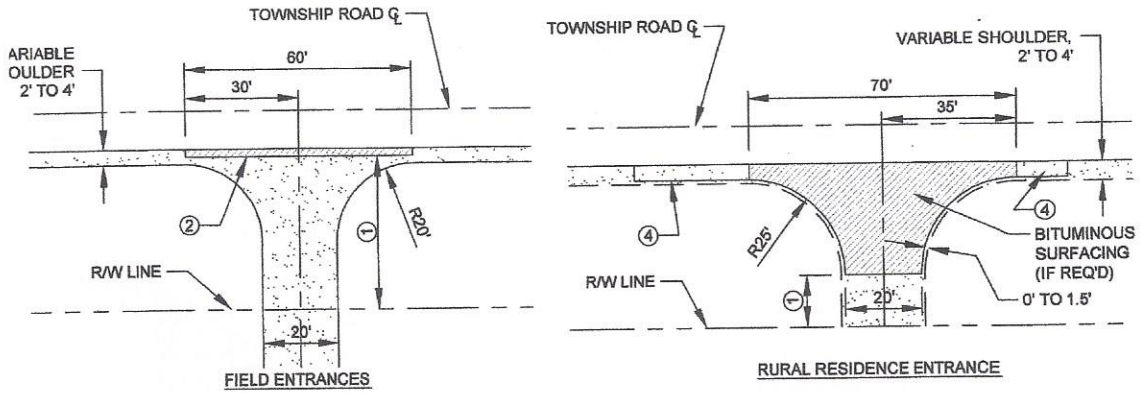

- ① Surfacing to match existing conditions. Where there is no surfacing, place gravel beyond bituminous surfacing to R/W line.
- ② If req'd, place 2 ft. wide bituminous surfacing as directed by engineer.
- ③ 8% max. commercial; 15% max. residential.
- ④ The use of paving similar to commercial entrances may be appropriate for some residences. As shown in plans or directed by the engineer.

APPROACHES AND ENTRANCES

TODD TOWNSHIP

RECOMMENDED MINIMUM SECTIONS FOR TOWNSHIP MAINTAINED ROADWAYS

CONSTRUCTION NOTES:
If topography and constructed grade permit slope roadway toward island. Sign showing one-way traffic to the right. Right-of-Way shall be extended 33 feet outside the centerline of the roadway around the island.

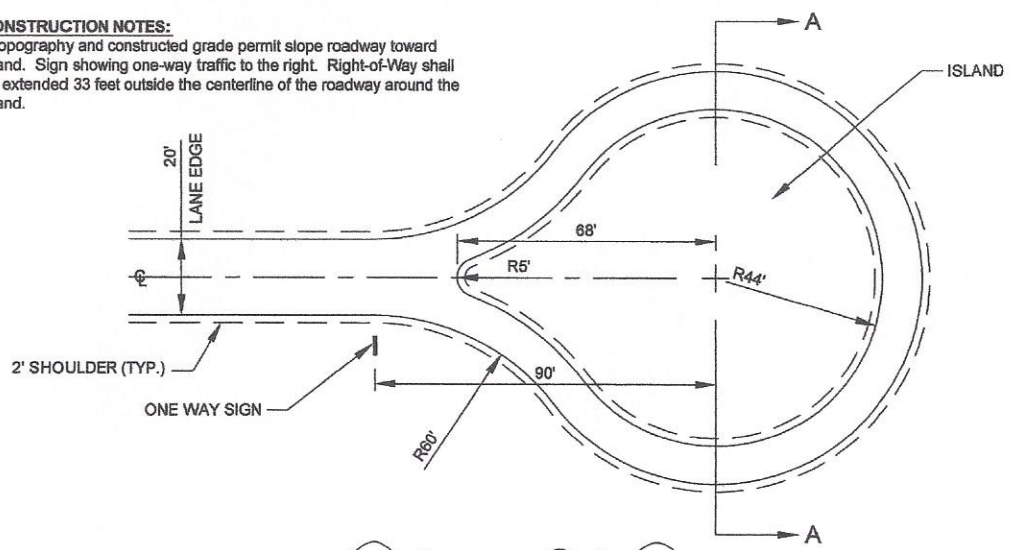

Cul-de-sac infiltration island accepts stormwater from surrounding pavement. Note flat curb.

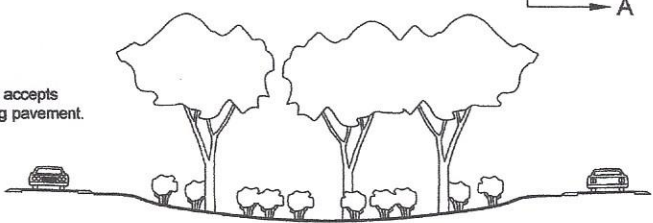

SECTION A-A CUL-DE-SAC WITH CENTER ISLAND

TODD TOWNSHIP

RECOMMENDED MINIMUM SECTIONS FOR TOWNSHIP MAINTAINED ROADWAYS

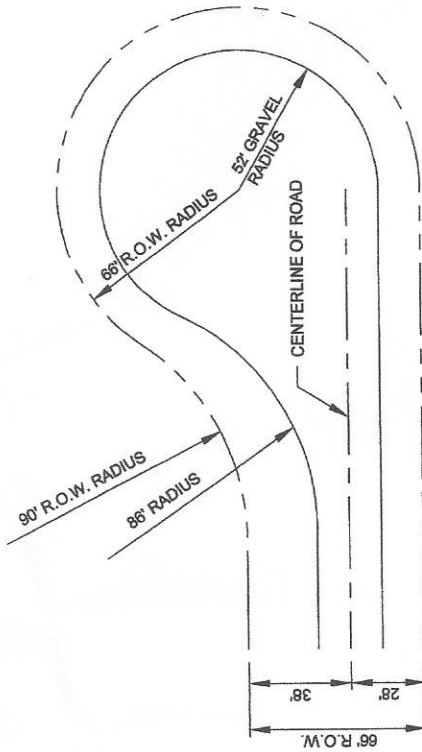

OFFSET CUL-DE-SAC

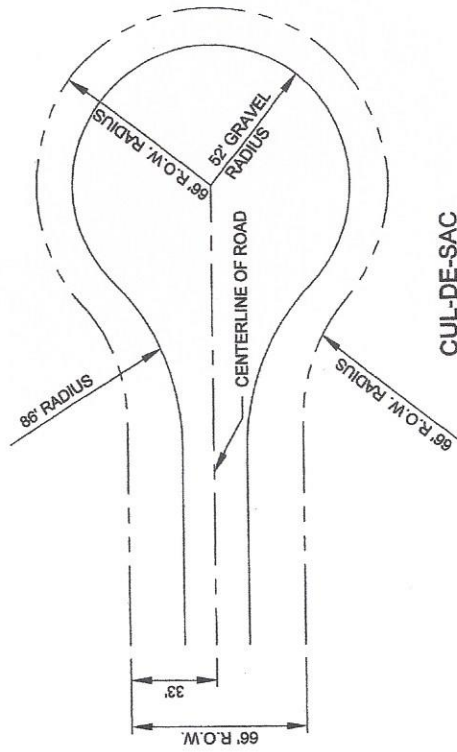

CUL-DE-SAC

TODD TOWNSHIP

RECOMMENDED MINIMUM SECTIONS FOR TOWNSHIP MAINTAINED ROADWAYS

TURNAROUNDS (ONLY WHEN APPROVED BY TOWNSHIP)

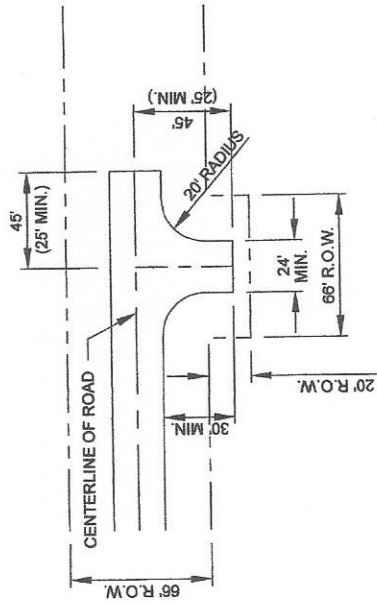

BRANCH TYPE TURNING AREA

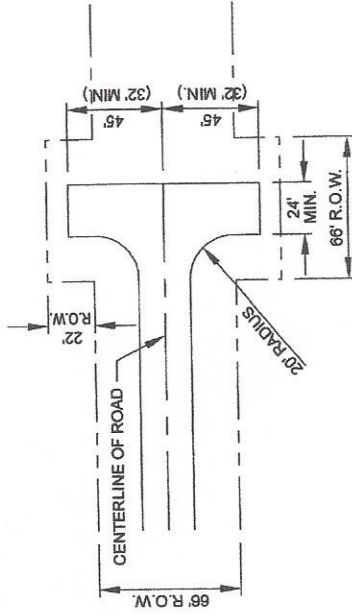

STANDARD T-TYPE TURNING AREA

TODD TOWNSHIP

RECOMMENDED MINIMUM SECTIONS FOR TOWNSHIP MAINTAINED ROADWAYS

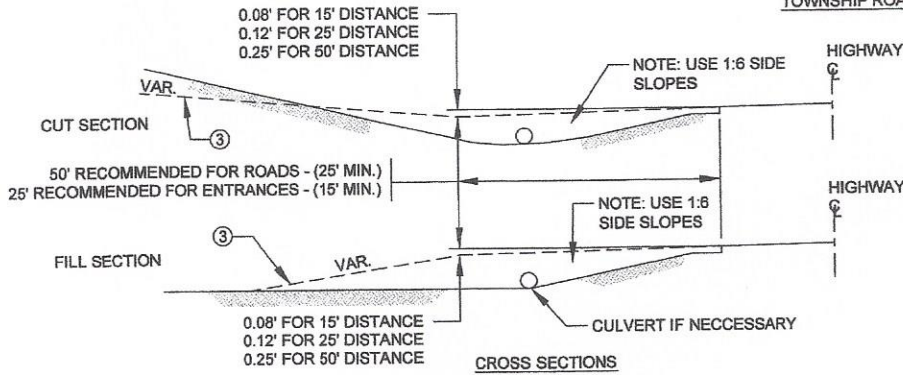
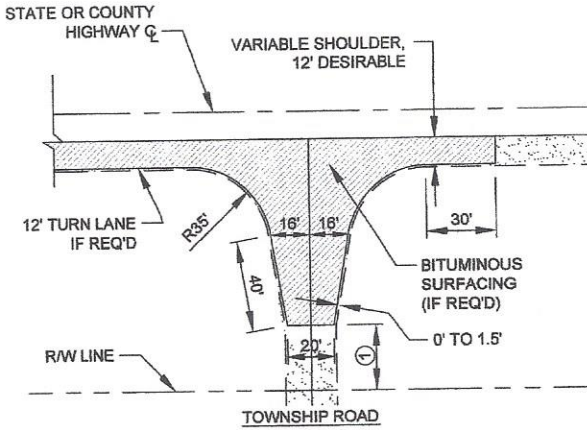
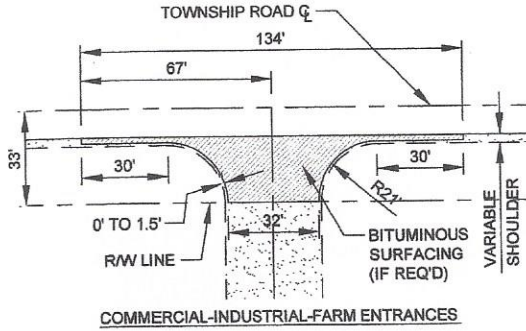

- ① Surfacing to match existing conditions. Where there is no surfacing, place gravel beyond bituminous surfacing to R/W line.
- ③ 8% max. commercial; 15% max. residential.

APPROACHES AND ENTRANCES