

Todd Township

"Where the good living begins"

Attn: Todd Township Zoning Administrator

Hometown Planning, 203 Broadway Street, Alexandria, MN 56308

Toll Free: (888) 439-9793 or Local Phone: (320) 759-1560

Email: oleson@hometownplanning.com

APPLICATION FOR ROAD AND ACCESS PERMIT

Parcel ID No _____

Permit Number: 20____ - ____

The attached Ordinance is considered part of this permit form.

Owner Name: _____

Mailing Address: _____

Telephone(s): _____

Applicant Name: _____ Telephone(s): _____

Address and Location of Driveway/ Access: _____

Attach Drawing of proposed sight for access: Show property pins and distances.

911 Numbers: _____

Purpose of Driveway / Access: ___Residence ___ Commercial (Specify Type) _____ Other (Specify Type)

Property Platted? ___No ___Yes Date Proposed Entrance Needed _____

Number of present driveways to property: _____

Contractor: _____ Address: _____

I/we, the undersigned, herewith make application for permission to construct the driveway / access at the above location, said entrance to be constructed in accordance with Todd Township Road and Access Ordinance adopted April 2011 and amended on 08.12.13 and 01.09.19, and to any special provisions included in the permit. It is agreed that all work will be done to the satisfaction of the Town Road Authority. It is further agreed that no work in connection with this application will be started until the application is approved and the permit issued. It is expressly understood that this permit is conditioned upon replacement or restoration of the town road to its original or satisfactory condition. It is further understood that this permit is issued subject to the approval of the Todd Township Road Authority.

Date

Signature of Applicant

8. All Township residential graveled as well as any new subdivision roads shall be designed to meet a minimum nine-ton pavement standard.
9. After December 2009, all "through" roads, commercial or industrial classified roads shall be designed to meet a minimum ten-ton pavement standard.
10. Whenever a new subdivision road abuts or contains an existing or proposed County or State highway, a frontage road with a minimum sixty-six foot (66 foot) right-of-way is required so driveways will not have direct access to the major highway.

3.2. Road Ditches & Erosion Control

1. Side ditch and embankment construction shall provide adequate roadbed drainage including installation of centerline culverts as required, with a minimum centerline culvert size of eighteen inches or larger dependent upon road classification and hydraulic need. In-slopes shall not be constructed steeper than three feet horizontally to one foot vertically [3: 1]. Back slopes shall not be constructed steeper than two feet horizontally to one foot vertically [2:1], unless approved by the Township. The top of the back slope shall be blended into the natural ground line.
2. On all roadbed cut and fill areas in excess of six feet, additional right-of-way or slope easements may be required in order to construct proper slopes to prevent serious erosion. In cases where significant cut or fill is necessary, the use of erosion control blanket measures and/ or best management practices [BMPs] may be required by the Township to stabilize the soil.
3. All construction areas will be protected with proper drainage to prevent damage to the actual roadbed. Within the construction area three inches of topsoil and seeding shall be required to prevent erosion, using MN/DOT standard specification for a common "Ditch Mix" [Mixture 270].
4. All graded areas from road construction shall be protected from erosion using necessary Best Management Practices, such as hay bale checks, sediment basins, dike checks, fiber bags, triangular silt dikes, silt fences, etc., as a minimum.

3.3. Cul-de-Sacs

1. Cul-de-sacs shall have a terminal turn around which shall be provided at the closed end, with a minimum turn around diameter of one-hundred four feet (104 feet). Cul-de-sacs will be required to have a minimum road right-of-way radius of sixty-six (66) feet. (See attached profile drawings).
2. In the instances of temporary cul-de-sac, where a road is terminated pending future extension in conjunction with a future subdivision, a temporary turn around facility shall be provided at the closed end, in conformance with cul-de-sac requirements. The temporary cul-de-sac must be maintained and left in place until the future extension is completed with proper signage to show that a future road may be connected. No mailboxes are to be placed on temporary cul-de-sacs.
3. All cul-de-sac construction must conform to requirements for ditching and banking as in section 3.1.3. under Road Beds & Embankments.

SECTION FOUR

DRIVEWAY AND ACCESS STANDARDS

4.1. General Terms & Conditions

No driveway, approach or entrance shall be constructed, **or used**, unless the owner of the land served by same shall have in his possession a valid permit signed by Todd Township. The person

constructing such entrance, if different from the landowner, shall have in his possession a copy of said permit during said construction. The issuance of this permit is to be conditioned on such items as public safety, drainage, sight distances, and esthetics in addition to consideration of convenience and necessity to the landowner.

This requirements of this section shall not apply to driveways, approaches or entrances which serve only propert(ies) in other townships or cities, unless otherwise specified by agreement with the adjoining jurisdiction.

The following standards shall apply when considering a new or re-located driveway entrance or any other access entrance onto an existing Township road and through the Township road right-of-way.

1. Driveways accessing onto township entrances prior to an intersection must meet Township and MN/Dot safety specifications.
2. If driveway, approach or entrance enters onto a Township road which has been paved, the property owner(s) will be required to pave the ROW portion to the parcel so that it will interconnect with the Township road according to attached drawings.
3. A driveway should intersect the Township road at a right angle. A residence driveway should be a minimum of twenty feet (20 feet) wide and not more than twenty-four feet (24 feet) wide, measured at right angles to the centerline of the driveway. [See attached drawings in Appendix A].
4. Driveways shall be meet a minimum setback of twenty (20) feet from the side property lines as projected into the right-of-way, unless requested otherwise and approved by the Town Board.
5. Non-residence driveway widths (i.e. field, commercial and industrial accesses) shall be reviewed and approved by the Town Board on a case-by-case basis. In determining whether or not a driveway for a non-residential use should be required to conform to higher standards, the Town Board shall take into account the following non-exclusive list of factors; the traffic generated by the use, the type of vehicles using the access, the location of the proposed access, and the hours of operation of the use. [See attached diagrams in Appendix A].
6. Minimum spacing between driveways at the road shoulder will be one hundred feet (100 feet), unless otherwise approved by the Town Board.
7. One driveway per parcel is allowed. More than one driveway per parcel may be allowed by the Town Board if the parcel frontage on a single road is greater than one thousand three hundred and twenty feet (1320 feet) or, if more accesses are needed due to fence-lines or geographical features.
8. Standard swing arm mailboxes and standard swing arm support posts may be located within the Township road right-of-way. However, the Township is not responsible for damage to mailboxes or posts during road maintenance or snow plowing.
9. All new mailboxes will be required to conform to State of Minnesota Department of Transportation mailbox support (swing-away type), a copy of which is attached as Appendix B. Further, a mailbox will be required to meet the necessary setbacks and heights as shown on the example and as required by the U.S. Postal Service (USPS). **Amended 08.12.2013**
10. In addition to the above, mailboxes not conforming to the swing-away standard in Appendix B and/or USPS standards shall be replaced and constructed to the required standards at the expense of the private landowner when either of the following **happens**: **Amended 08.12.2013**
 - a. A new road is constructed and will be taken over by the Township.
 - b. The Township constructs and paves a new road.

- c. The Township takes over maintenance of an existing road.

4.2. Construction and Maintenance of Driveways and Access Entrances

The following rules will apply to construction and maintenance of driveway and access entrances onto an existing Township road [See Appendix C for different access entrances];

1. All work done within the Township road right-of way is subject to approval by Township Road Authority (Board) or the Town's duly authorized representatives.
2. The Township Road Authority shall determine the size, number and type of culverts necessary to ensure proper road drainage, but at a minimum all culverts shall be galvanized steel, twelve inches (12 inches) in diameter, with length sufficient for the width of said driveway, and shall be constructed with flared ends. The Town Board may require safety cross bars on culvert end sections in cases where deemed necessary. In known high flow areas, culvert openings larger than 27" diameter will be permitted within the obstacle free area of the right-of-way on a case by case basis.
3. No driveway or access entrances shall cross a wetland unless a permit authorizing such impacts to the wetland has been obtained from the relevant governmental authority in advance and a copy of such permit has been submitted to the Township by the applicant.
4. Proper and adequate drainage facilities shall be provided as required by the Township. Modifications to the present ditch system may not be done without prior approval by the Township.
5. No obstructions shall be constructed or planted in the Townships' rights-of-way without Town Board approval. Obstructions include but are not limited to the following: retaining structures, posts, trees, shrubs, wood trash piles, boulders, equipment, fencing, and other such items.
6. The driveway and/or access entrance must be constructed with, at a minimum, four inches (4) of Class 1 aggregate or an approved equivalent. If determined necessary other surfacing (i.e. pavement, concrete, etc.) may be required by the Township Board.
7. No foreign material such as dirt, gravel, clumps of clay, mud, sand, soil washings, building materials or bituminous materials shall be left or deposited on the Township road during or after construction of driveway or installation of drainage facilities. Failure to clean up such dirt and debris may result in with additional charges for costs incurred by the Township.
8. All entrance or approach construction shall conform to section 3.1 Road Bed and Embankments.

4.3. Permit Requirements

1. When completed and issued, a Township road application for a driveway and/or access entrance permit, along with the permit fee and a construction deposit, shall be delivered to the Township Zoning Administrator.
2. An approved permit will be required **prior to commencement of construction** of any entrance onto a Todd Township road. Both the permit and construction fees will be submitted prior to issuance of permits to assure satisfactory completion of the construction.
3. The driveway and access permit fee and construction deposit shall be set from time to time by a resolution of the Town Board.

4.4. Inspection Prior to Construction

1. Upon receipt of application, the access and/or driveway entrance location will be inspected to determine culvert and any special requirements.

2. If the access and/or driveway location is satisfactory and no culvert is required, the approval notice will indicate said fact.
3. When work on a driveway approach is commenced, traffic on the Township road must be protected, and flags and/or proper barricades must be placed in accordance with the most current edition of the standards used in the Manual on Uniform Traffic Control Devices, which is on file with the Hubbard County Engineer's office.

4.5. Final Inspection

1. Upon completion of the driveway and/or access approach and/or culvert installation, including turf restoration, the approach shall receive a final inspection by the Township. Prior to approval by the Township, all necessary conditions of this ordinance shall have been met. The disturbed area within the right-of-way shall be seeded but need not have established grass cover prior to approval by the Town Board.
2. Return of Construction Deposit. Once the final inspection has been completed and approved by the Town Board, the construction deposit will be returned. In the case where inspection is done and not approved, applicant will complete the needed changes, or the construction deposit will be used to affect the necessary changes to the driveway.

SECTION FIVE

ENFORCEMENT OF ORDINANCE

5.1. Town Board Enforcement

1. The Town Board or the Board's designee (i.e. Township Zoning Administrator or road maintenance contractor) shall enforce this Ordinance, except that the Town Board shall enforce those provisions specifically identified as needing approval by the Town Board. The Town Board's designee shall initiate appropriate action for any violations of this Ordinance at the direction of the Board and through the Township Attorney as deemed necessary.
2. Whenever the Town Board or the Board's designee determines that a violation has occurred or exists on property within the township, the owner or occupant of such property shall be notified of the fact in writing. The notice shall be served in person or by certified or registered mail. If the property is not occupied and ownership of the property cannot be ascertained, or in the event that personal service cannot be made, or certified or registered mail is returned, notice is deemed served when posted on the property or deposited in the U.S. Mail.
3. In the event that an improper or poorly constructed entrance or access is deemed by the Township to constitute an immediate danger, the Township may initiate immediate removal of such hazard without prior notification of the owner or occupant of such property. As soon thereafter as practical the Township shall provide written notice to the owner or occupant of the premises of the actions taken. The notice shall be served in person or by certified or registered mail. If the property is not occupied and ownership of the property cannot be ascertained, or in the event that personal service cannot be made, or certified or registered mail is returned, notice is deemed served when posted on the property or deposited in the U.S. Mail. All expenses incurred by the Township to remove the hazard will be charged against said parcel and will be the responsibility of the owner.

5.2. Thirty Days Written Notice

A written notice pursuant to Section 5.1.2 shall specify the violation and the steps required to correct said violation and the time, not to exceed thirty days (30 days) within which the corrections must be

TODD TOWNSHIP

RECOMMENDED MINIMUM SECTIONS FOR TOWNSHIP MAINTAINED ROADWAYS

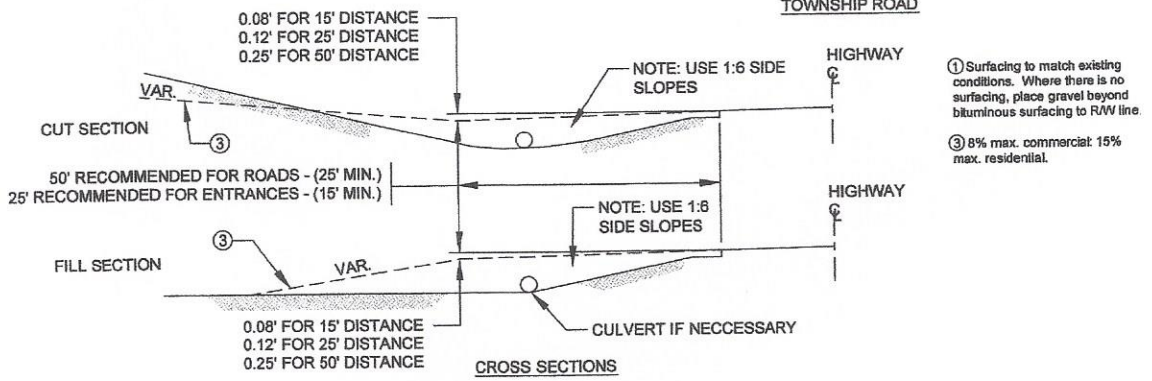
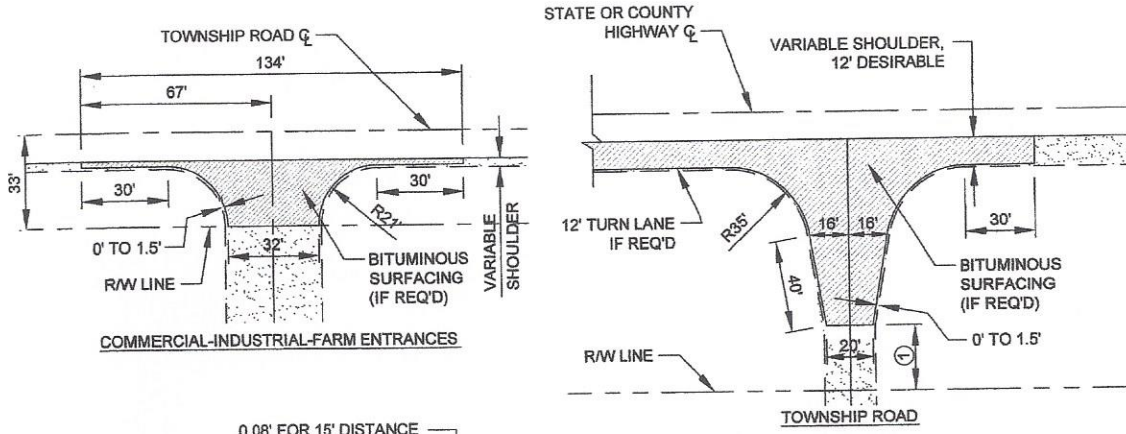

- ① Surfacing to match existing conditions. Where there is no surfacing, place gravel beyond bituminous surfacing to R/W line.
- ③ 8% max. commercial; 15% max. residential.

APPROACHES AND ENTRANCES